

Micro Engineering Turnout Templates

Ladder Track System

HO #5d Intermediate Ladder

Turnout Specifications

- Frog angle: #5, 11.421°
- Diverging stub angle: 16.2°
- Turnout length: 7.489"
- Track centerline radius, closure area: 22.9"
- Track centerline radius, diverging stub: 22.1"
- Tie width: .094" (proto 8")
- Tie thickness: .078" (proto 7")
- Tie lengths: 1.157" to 2.261" (proto 8'-5" to 16'-5")
- Tie spacing: .226" (proto 20")
- Switch point throw: .080"

Notes

- The #5d Intermediate Ladder turnout is one of five different #5 turnouts of the Micro Engineering Ladder Track System. For more information go to microengineering.com.
- Turnouts have a sprung switch rail assembly.
- Turnouts are DCC compatible.

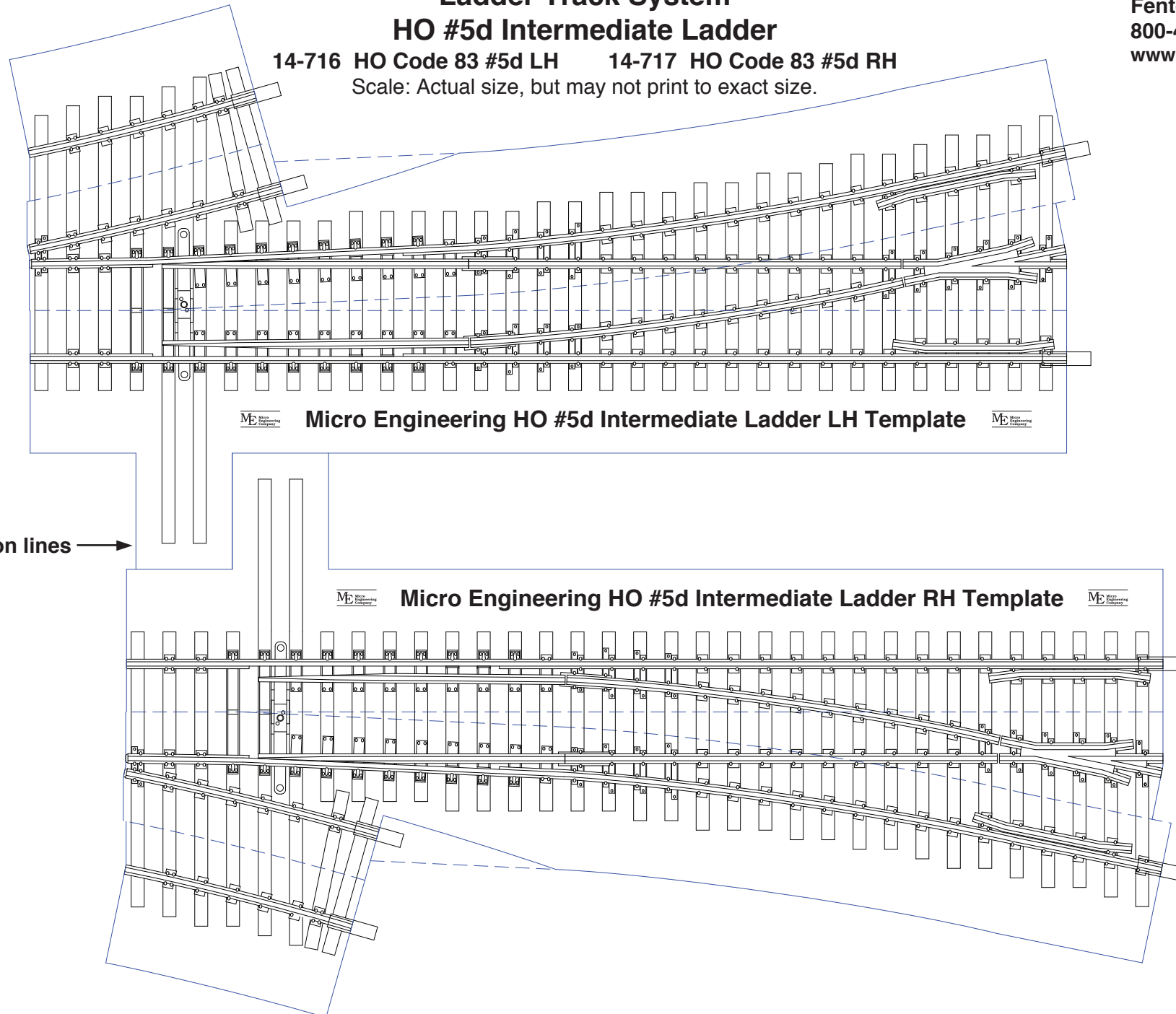

Cut out templates on lines →

Printing instructions

- This is an Adobe .pdf document and requires a program that can open and print pdf files such as Adobe Acrobat or Adobe Reader.
- Print the page 1 template on **legal size** paper (8½" x 14") or print the page 2 template on **letter size** paper (8½" x 11").
- Printer settings to use: Page 1 or 2; landscape layout; actual size; 600 dpi; turn off all other page scaling & fitting options; turn off choose paper source by pdf page size.
- Although the drawings are actual size, they may not print to exact size depending on the specific printer and printer settings.
- After printing, confirm the size of your template by measuring the straight stock rail and comparing it to the turnout length above.

Micro Engineering Turnout Templates

Ladder Track System

HO #5d Intermediate Ladder

14-716 HO Code 83 #5d LH 14-717 HO Code 83 #5d RH
Scale: Actual size, but may not print to exact size.

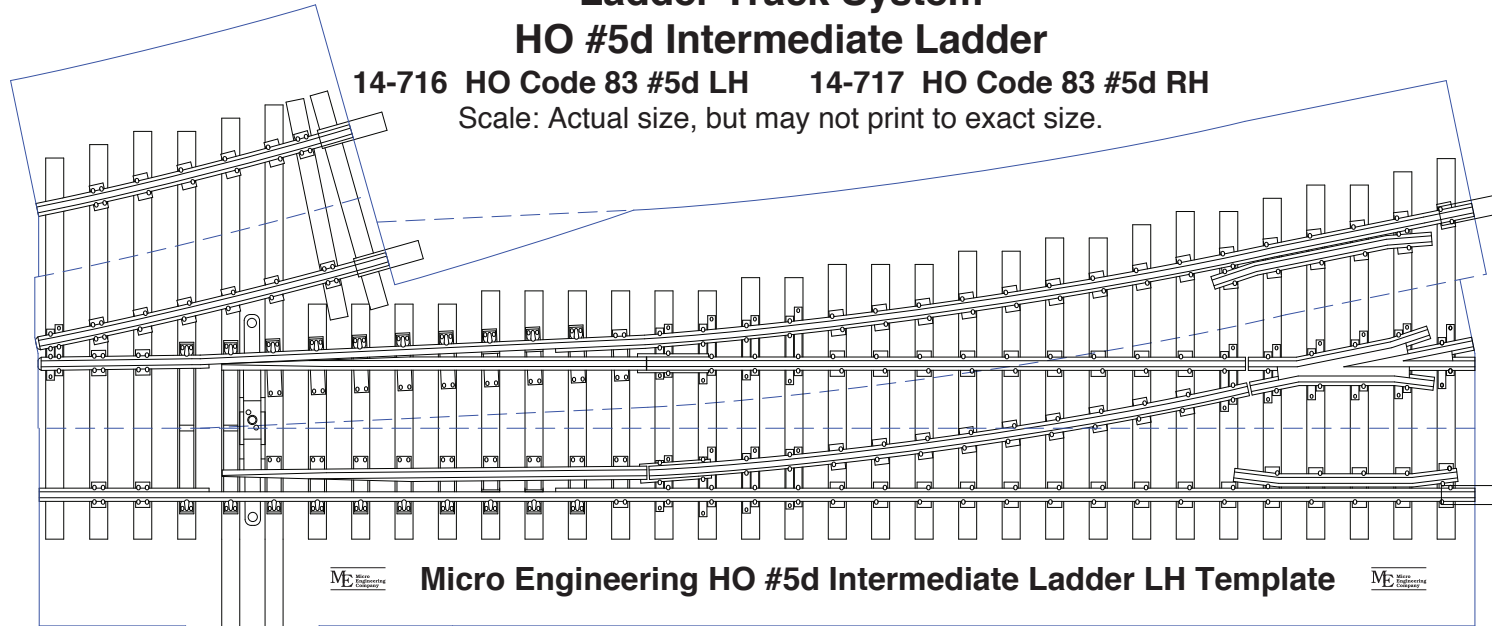

Micro Engineering HO #5d Intermediate Ladder LH Template

Cut out templates on lines →

Page 2 printing instructions

- This is an Adobe .pdf document and requires a program that can open and print pdf files such as Adobe Acrobat or Adobe Reader.
- Print this template on **letter size** paper (8½" x 11") in Landscape layout.
- Printer settings to use: Page 2; landscape; actual size; 600 dpi; turn off all other page scaling and fitting options; turn off choose paper source by pdf page size.
- Although the drawings are actual size, they may not print to exact size depending on the specific printer and printer settings.
- After printing, confirm the size of your template by measuring the straight stock rail and comparing it to the turnout length listed on page 1.

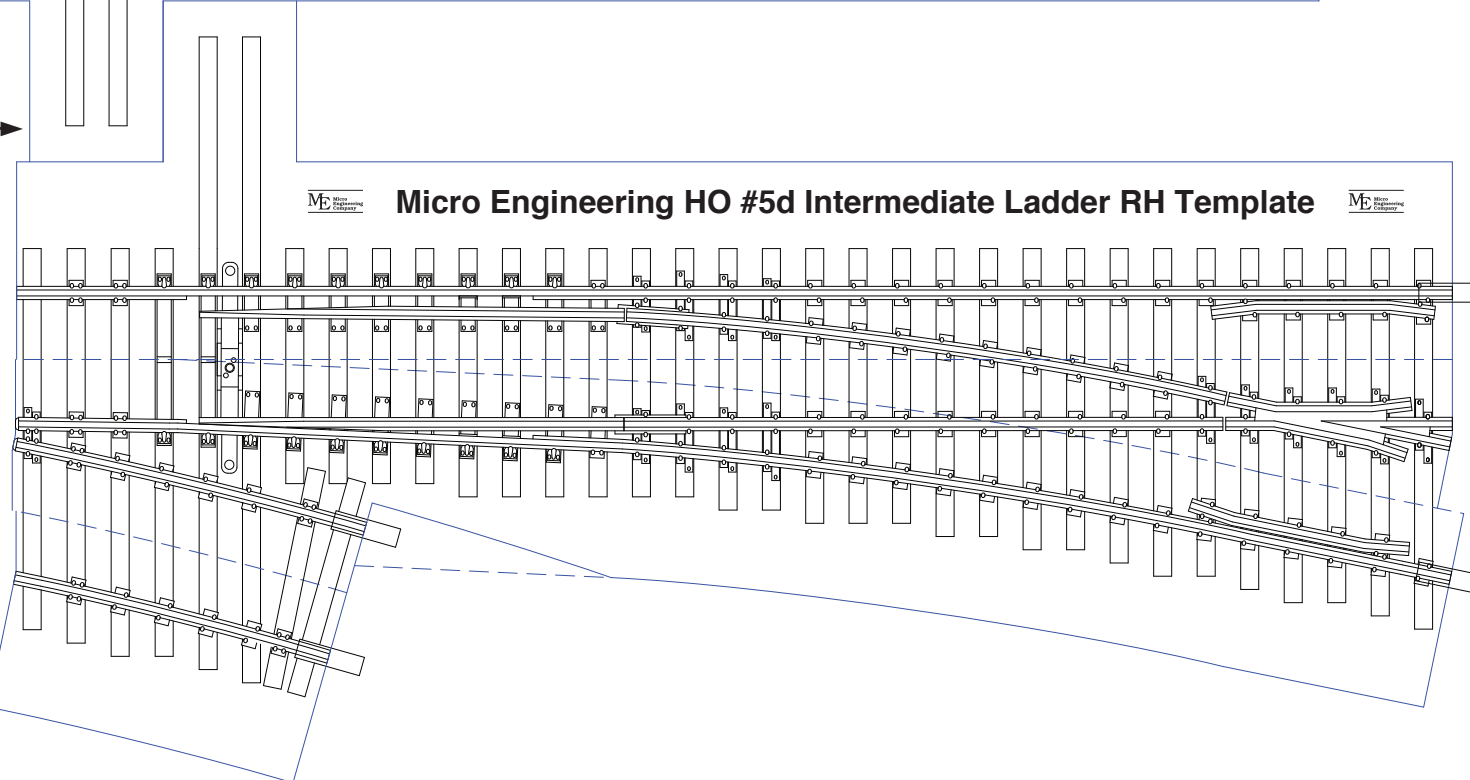

Micro Engineering HO #5d Intermediate Ladder RH Template